

- ✓ Quadrature Counter DC-500kHz
- ✓ Angular Counter
- ✓ Up Down Counter, Timer
- ✓ Frequency Counter 0.003Hz-500 kHz
- ✓ Free scalable Display
- ✓ Four Set Points Relays
- ✓ Two Analog Outputs
- ✓ RS232 and RS485 addressable
- ✓ Last Reading Memory



Orbit Controls OC7171A is a 6-digit counter with programmable functions for Quadrature Positioning Counter with bi-directional incrementing, Up-Down Counter and Tachometer-Frequency Counter. The instrument is designed for industrial applications in connection with digital encoders, magnetic pick-ups and other industrial pulse sources.

The programming with the keypad contains the selection of the process parameters. In the function Timer the display measures the period time of the input pulses.

The function of Quadrature Counter, Updown Counter, Tachometer or Timer is programmable with the keypad.

Incremental-Quadrature Counter is designed for fast positioning applications by using two 90° phase shifted A and B signals from linear or rotative incremental resolvers. The counting direction is automatically derived from the phase shift of the two signals. The display increments with each edge of A and B signals.

Up-Down Counter can be used for bi-directional counting applications. The pulses to be counted are connected to the input A. The logic signal at the input B determines the counting direction up or down. Up-Down mode of operation can be selected with the keypad. The display counts up when the pulses are connected to the input A and counts down when the pulses are connected to the input B.

Tachometer - Frequency counter will be used for measurements of RPM, speed, frequencies and other dynamic applications at which frequency is the input.

Angular Counter operates with two 90° phase-shifted signals A and B from rotational resolvers and measures the angle from 0 to 360°. The resolution of the display depends on the number of pulses per revolution of the used resolver. The reference - zero - signal from the resolver might be used to set the display to zero.

The display is selectable in required process units. The input signal can be entered from one or two signal sources. When an incremental resolver is connected, the display can bi-directionally indicate RPM by utilizing the sign at the display.

Floating Point Arithmetic permits practically unlimited display capacity. The programmed decimal point is automatically positioned to the right when the display arrives at full capacity. When the counts at the display exceed the value of 999999 with decimal point behind the LSD, the display switches into exponential expression, e.g. 1234E6.

Preset has 6 digits with decimal point and sign. The programmed value can be inserted into the display with the keypad. The display starts counting at the Preset.

Scale of the display can be achieved with both, multiplication and division. Multiplication has free programmable 6 digit number with decimal point and sign. The division has constants :1 to :100 000 selectable in decimal steps. By using the scale, the display can be programmed in any required process unit like mm, inch, LPM, Gallons, m/sec, RPM etc.

Averaging Filter has filter constants programmable from 1 to 99 and permits the instrument to measure signals from resolvers which vibrate or signal sources at noisy environments.

Last Reading is automatically stored when the instrument is switched-off from the supply. When the power is applied again, the display starts counting at the stored last reading value.

Two Analog Outputs, two serial Data Ports and additional two Set Points with transistor outputs or mechanical relays can be optionally ordered. They increase the universality of the instrument in many industrial applications.

PASS Password permits entering the menu and programming of the instruments parameters.

PRESET is a 6 digit additive constant (Offset) with decimal point and sign.

SCALE is a 6 digit multiplicative constant with decimal point and sign.

DSCALE is a dividing constant selectable from :1 to :800 000.

ORDER determines the display resolution by placing the decimal point from X.XXXXX to XXXXXX.

FBASE is activated in the Tachometer-Frequency counter function. It determines the measuring time from 300ms to 160 sec.

OBASE is activated in the Tachometer-Frequency counter function. It determines the time between two consecutive input pulses prior the display resets to zero. The reset is programmable from 1.2 to 320 sec.

PASSWORD permits setting of the password as one of 20 firm memorized combinations.

ANALOG are two analog outputs 0/4-20mA and $\pm 10V$. With the keypad they can be assigned to any two display values.

FILTER is an averaging filter with filter constants free programmable from OFF to 99.

DATA BUS RS232 and RS485. Up to 31 instruments can be connected on one RS485 data bus.

SPECIFICATIONS OC7171A

Display

0... ± 999999 , 7 segment LED red, 14.7 mm.

Inputs

DC-500kHz, positive logic 5V protected to 48V.

Preset

Additive constant (offset) is program-able from 0 to ± 999999 with decimal point and sign. The preset can be inserted into the display with the keypad.

Reset

The display can be set to zero with the keypad or with the external positive signal 5 ... 48V.

Analog Output (Option)

Voltage: 0 ... $\pm 10V$

Current: 0/4-20mA.

Resolution: 12bit.

Isolation: 250V rms.

Terminals

Pluggable screw terminals

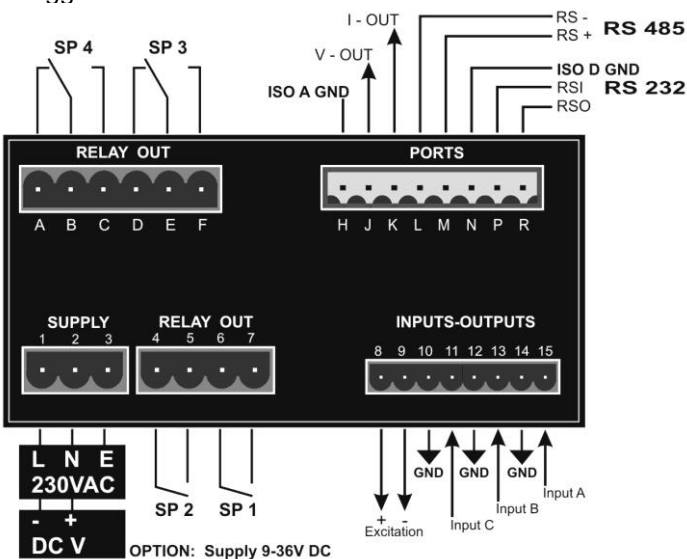

Data output (Option)

RS232 and RS485 (4 wire), 8 bit, no Parity, 1 Start, 1 Stop, 600-19200 bd, Addresses 00 - 31. Isolation 250V RMS.

Set Points (Option)

Four Set Points with programmable Hystereze. Four Relays 5A-230VAC or four NPN open collectors 60V/100mA.

Excitation

5-24V/40mA adjustable.

Instruments with DC Supply can optionally have non isolated excitation adjustable from 2V to max. used supply voltage.

Supply

115/230V $\pm 10\%$, 50-60Hz, 9VA.

Option: 9 - 36 V DC, 4 W.

Cabinet IP65 from the front

DIN 48x96mm, 100mm depth behind the front.

Panel cut-out 45x90 mm.

STANDART COUNTER

The standard counter contains 230VAC or 115VAC supply and adjustable excitation 5-24V.

OPTIONS

- * SP1, SP2 Set Point Relays
- * SP3, SP4 additional two Set Point Relays
- * Analogue Outputs 0/4-20mA and 0... $\pm 10V$
- * Serial Data Ports RS232 and RS485
- * Supply 9-36VDC
- * Customized Software